

DEPARTMENT OF FACILITIES

DANNY CLEMENS, DIRECTOR
TRACY PARSLEY, MAINTENANCE SUPERVISOR
THOMAS STOKES, CUSTODIAL SUPERVISOR
GEORGE BROCK, ENERGY MANAGER

MEMO

TO: Dr. Jesse Bacon, Superintendent
FROM: Danny Clemens, Director of Facilities
Date: August 19, 2024
RE: Bernheim - Change Order 25 - Miscellaneous Interior Framing **DC**

This Change Order includes finishing work to account for existing conditions found during construction. Three Change Order Requests are included in this Change Order. (1) COR 33 -includes work to modify the varsity locker room layout to account for an existing roof drain leader that had to remain in place; (2) COR 34 includes work to address CMU finishing post-Demolition. It was determined that additional stud framing and drywall finishes were needed to cover CMU and unify the appearance of the larger flex room adjacent to the Media Center. (3) COR 36 is a credit for a different ACT ceiling tile - it was discovered during construction that the incorrect ceiling type was installed at Phases 1 and 2. SKA reviewed the installed tile and determined it would not compromise the performance of the ceiling system. BCPS Facilities agreed to credit for this work rather than tile replacement.

I recommend approval of this request.

Attached paperwork is listed below with action items noted for each:

- G701-2017 - Change Order 25 - Misc Interior Framing - for Board Signature
- CO 25 - FACPAC - Misc Interior Framing - For Board Signature
- COR-34 RFP #25 Media Center CMU - No action – for Board Reference.
- COR-36 Deduct for Ceiling Tile- No action – for Board Reference.
- G701-2017 - Change Order 25 - Misc Interior Framing- No action – for Board Reference.

OUR MISSION IS TO INSPIRE AND EQUIP OUR STUDENTS TO SUCCEED IN LIFE

BULLITT COUNTY PUBLIC SCHOOLS IS AN EQUAL EDUCATION AND EMPLOYMENT INSTITUTION

Wen Wood



AIA Document G701® - 2017

Change Order

PROJECT: *(Name and address)*
Bernheim Middle School Renovation
700 Audubon Drive, Shepherdsville, KY
40165

CONTRACT INFORMATION:
Contract For: General Construction
Date: June 19, 2023

CHANGE ORDER INFORMATION:
Change Order Number: 025
Date: August 26, 2024

OWNER: *(Name and address)*
Bullitt County Public Schools Board of
Education
1040 Hwy 44 East
Shepherdsville, KY 40165

ARCHITECT: *(Name and address)*
Studio Kremer Architects, Inc.

1231 S. Shelby Street
Louisville, KY 40203

CONTRACTOR: *(Name and address)*
Calhoun Construction Services, Inc.

7707 National Turnpike
Louisville, Kentucky 40218

THE CONTRACT IS CHANGED AS FOLLOWS:

(Insert a detailed description of the change and, if applicable, attach or reference specific exhibits. Also include agreed upon adjustments attributable to executed Construction Change Directives.)

See CORs #33, 34 and 36 for scope of Work included in this Change Order.

The original Contract Sum was	\$	20,787,544.59
The net change by previously authorized Change Orders	\$	-493,489.63
The Contract Sum prior to this Change Order was	\$	20,294,054.96
The Contract Sum will be decreased by this Change Order in the amount of	\$	1,259.00
The new Contract Sum including this Change Order will be	\$	20,292,795.96

The Contract Time will be unchanged by Zero (0) days.

The new date of Substantial Completion will be

NOTE: This Change Order does not include adjustments to the Contract Sum or Guaranteed Maximum Price, or the Contract Time, that have been authorized by Construction Change Directive until the cost and time have been agreed upon by both the Owner and Contractor, in which case a Change Order is executed to supersede the Construction Change Directive.

NOT VALID UNTIL SIGNED BY THE ARCHITECT, CONTRACTOR AND OWNER.

Studio Kremer Architects, Inc.

Calhoun Construction Services, Inc.

Bullitt County Public Schools Board of
Education

ARCHITECT *(Firm name)*

CONTRACTOR *(Firm name)*

OWNER *(Firm name)*

Catherine N. Ward
SIGNATURE

SIGNATURE

SIGNATURE

Catherine Noble Ward, AIA
PRINTED NAME AND TITLE

Joel Pittard, Project Manager
PRINTED NAME AND TITLE

Dr. Jesse Bacon, Superintendent
PRINTED NAME AND TITLE

8-17-2024

DATE

DATE

DATE

FACPAC Contract Change Order Supplemental Information Form (Ref# 60541)

Form Status: Saved

Tier 1 Project: Bernheim Middle School -Renovation
BG Number: 23-051 District: Bullitt County (HB678) (071)
Status: Active Phase: Project Initiation (View Checklist)

Contract: Calhoun Construction Services, Inc., 0001, General Construction
Type: General Contractor Proposed

Change Order Number 25
Time Extension Required No
Date Of Change Order 8/26/2024
Change Order Amount To Date Decrease

Construction Contingency

Calculations below are project wide. Remaining negative Construction Contingency may require the submission of a revised BG1.

Current Approved Amount	\$1,261,761.60
Net Approved COs	\$-45,260.42
Remaining After Approved COs	\$1,307,022.02
Net All COs	\$57,433.58
Remaining After All COs	\$1,204,328.02

This Requested Change Order Amount (\$1,259.00)
+/-
Change In A/E Fee This Change Order \$0.00
+/-

Change In CM Fee This Change Order \$0.00

+/-

Remaining Construction Contingency \$1,204,328.02

Balance

Contract Change Requested By Architect/Engineer; Construction Manager; General Contractor; BCPS Facilities

Contract Change Reason Code Expansion of Scope; Found Condition; Reduction of Scope

Change Order Description And Justification

This Change Order includes finishing work to account for existing conditions found during construction. Three Change Order Requests are included in this Change Order. (1) COR 33 - includes work to modify the varsity locker room layout to account for an existing roof drain leader that had to remain in place; (2) COR 34 includes work to address CMU finishing post-Demolition. It was determined that additional stud framing and drywall finishes were needed to cover CMU and unify the appearance of the larger flex room adjacent to the Media Center; (3) COR 36 is a credit for a different ACT ceiling tile - it was discovered during construction that the incorrect ceiling type type was installed at Phases 1 and 2. SKA reviewed the installed tile and determined it would not compromise the performance of the ceiling system. BCPS Facilities agreed to credit for this work rather than tile replacement.

Cost Benefit To Owner

Work can commence with trades already on site and avoid the added cost of mobilization and general conditions. Also, this credits work that is included in the Contract, currently.

Contract unit prices have been utilized No to support the cost associated with this change order.

Detailed Cost Breakdown

Contract unit prices have not been utilized, provide a detailed cost breakdown which separates labor, material, profit and overhead.

Detail Item	Amount	Percent of Total
Labor	(\$8,125.00)	645.35%
Materials	\$6,666.00	-529.47%
Profit and Overhead	\$124.00	-9.85%
Bond Insurance	\$76.00	-6.04%
Cost Breakdown Total:	\$-1,259.00	

Cost for this Change Order supported No by an alternate bid or competitive price

quote

Explain Why

Work can commence with trades already on site and maintain the current Construction Schedule.

Change Order Supplemental Information Form Signature Page (Online Form Ref# 60541)

Catherine M. Ward

Architect

8-17-2024

Date

N/A

Construction Manager

Date

Lisa Lewis

Finance Officer

8-20-2024

Date

Local Board of Education Designee

Date

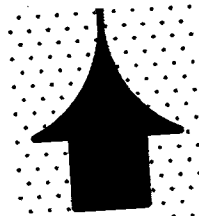

Change Order Request 33 - PCO #99 - RFP-24 Rain Leader RFI #68

**622-Bernheim Middle School Renovation
7/16/2024**



Summary of Work

RFP-24 Rain Leader per RFI #68

Scope - Subcontractor	Description of Scope	Cost
1 Bernheim Middle School Renovation		\$420.00
1.1 Doors & Frames -	RFP-24 - DPO ADD	\$0.00
1.2 Int Drywall & Framing Material - CCS Interiors -	RFP-24 - NO COST	\$0.00
1.3 Metal Lockers - Unistrut -	RFP-24 Rain Leader	\$420.00

\$420.00

Fee	10.00%	\$42
Bond	1.00%	\$5

Total Amount	\$467
---------------------	--------------

Approved By:

Date:

Submitted By:

Date:

7/16/2024



UNISTRUT
MIDWEST

(800) 586-4787
www.unistrut.biz

UNISTRUT MIDWEST

QUOTE

P.O. # S000073
(ADDED MATERIALS)

VENDOR ATTN: Tonya Lyons
CALHOUN CONSTRUCTION
7707 National Turnpike, Suite 400
Louisville, KY 40214

SHIP
TO

REF: Bernheim MS

SHIPPING METHOD	SHIPPING TERMS	DELIVERY DATE
		ASAP

QTY	ITEM #	DESCRIPTION	JOB	UNIT PRICE	LINE TOTAL
1		Corner Filler (INSIDE) - Slope Top Locker - 12" Deep			
1		Front Expansion Filler-Locker with NO Leg-12 Inch .. W x 72 Inch H			
1		End Finish Panels - Single Row - Slope Top - 16GA			
SUBTOTAL					\$420.00
LESS 5%					
TOTAL					\$420.00

Matt J Boissy

7/15/2024

Date

Cincinnati
1201 Hillsmith Drive
Cincinnati, OH 45215

Columbus
1973 Corvair Avenue
Columbus, OH 43207

Indianapolis
2125 South Keystone
Indianapolis, IN 46203

Detroit
4045 Second Street
Wayne, MI 48184



REQUEST FOR PROPOSAL

PROJECT:	Bernheim Middle School Renovation Shepherdsville, KY	REQUEST FOR PROPOSAL NO.:	24
OWNER:	Bullitt County Public Schools 1040 Highway 44 East Shepherdsville, KY 40165	DATE:	3-Jul-2024
TO CONTRACTOR:	Calhoun Construction Services, Inc. 7707 National Turnpike Louisville, KY 40218	ARCHITECT:	Studio Kremer Architects 1231 S Shelby Street Louisville, KY 40203
		ARCHITECT'S PROJECT NO.:	2022-36 BG# 23-051

Please submit an itemized quotation for changes in the Contract Sum and/or Time incidental to proposed modifications to the Contract Documents described herein.

THIS IS NOT A CHANGE ORDER NOR A DIRECTION TO PROCEED WITH THE WORK DESCRIBED HEREIN

Description:

Provide price proposal for the following:

- Item 1:** REFERENCE ASK-14 (IN RESPONSE TO RFI #68)
- Due to location of rain leader a 2 1/2" stud framed chase has added to conceal the pipe.
 - Door G107 has been changed from a left hand swing to a right hand swing.
 - The lockers have been modified to accommodate the new chase. This includes relocating two lockers to the plan East wall. An 8" CMU base shall be built under those relocated lockers. Refer to the interior elevations for further information on the metal lockers.

Attachments:

PDF: ASK-14

ISSUED:	3-Jul-2024	ARCHITECT:	studio kremer architects
CONTRACTOR:	Calhoun Construction Services, Inc.	BY:	Stephanie Satterfield

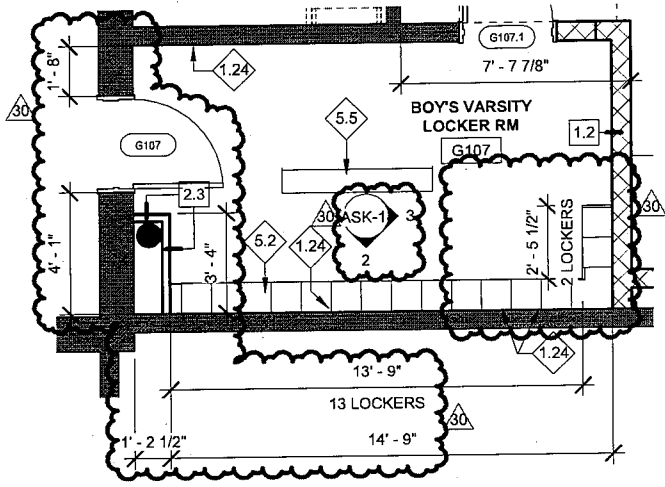

① ENLARGED PLAN- BOY'S LOCKER ROOM- RFP-24
1/4" = 1'-0"

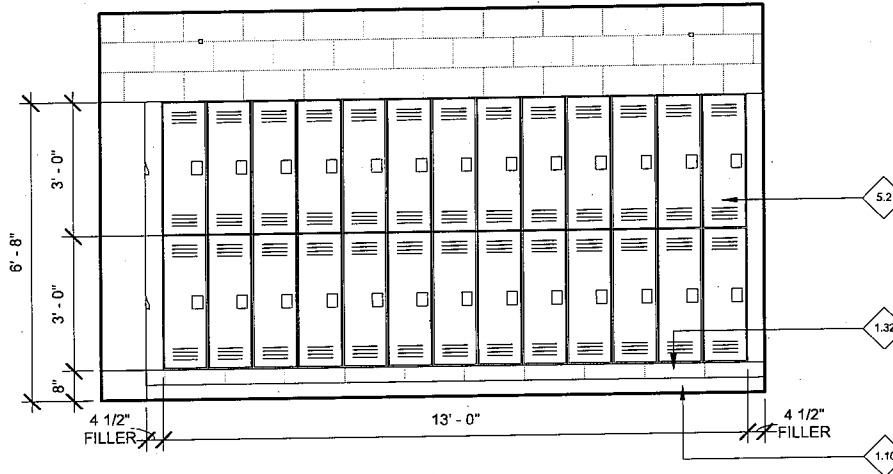

② ELEVATION - BOY'S VARSITY LOCKER RM- 1
3/8" = 1'-0"

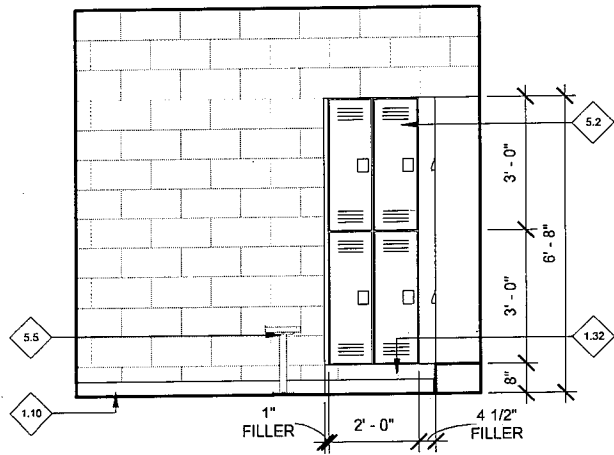

③ ELEVATION - BOY'S VARSITY LOCKER RM- 2
3/8" = 1'-0"

KEYNOTE LEGEND

1.10	WALL BASE, REF. FINISH SCHEDULE.
1.24	WHERE EXISTING PARTITION HAS BEEN REMOVED, PATCH ALL ADJACENT AND DISTURBED SURFACES TO MATCH EXISTING CONSTRUCTION. IF MASONRY, MATCH EXISTING BOND PATTERN AND TOOL JOINTS TO MATCH ADJACENT CONSTRUCTION, TOOTH INTO EXISTING MASONRY. PAINT.
1.32	8" CMU LOCKER BASE.
5.2	NEW DOUBLE STACKED LOCKERS INSTALLED ON NEW CMU BASE. REFER TO 1/A7.3 FOR FURTHER INFORMATION.
5.5	NEW FLOOR MOUNTED BENCH.

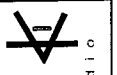

studio kremer architects
1231 S Shelby St, Louisville, KY 40203
602-498-1100 FAX 602-498-1100 s t u d i o

BULLITT COUNTY PUBLIC SCHOOLS
BERNHEIM MIDDLE SCHOOL RENOVATION

700 Audubon Drive

RFP-24

Title / description:
CHASE IN BOY'S LOCKER RM

Project no.: 2022-36 RFP #08
Date: 07/03/2024

Drawn by: SSS
Checked by: SSK
As indicated Reference DWG: AS.7

ASK-14

7/27/2024 3:25:16 PM

Change Order Request 34 - PCO #100 - RFP #25 Media Center CMU Wall

622-Bernheim Middle School Renovation

7/17/2024



Summary of Work

RFP #25 Media Center CMU Wall

Scope - Subcontractor	Description of Scope	Cost
1 Bernheim Middle School Renovation		\$7,061.00
1.1 Unit Masonry - McDuffie -	Break Metal	\$815.00
1.2 Int Drywall & Framing Material - CCS Interiors -	COR 14	\$6,246.00

\$7,061.00

Fee	10.00%	\$82
Bond	1.00%	\$71

Total Amount	\$7,214
---------------------	----------------

No added markup on \$6,246

Approved By:

Date:

Submitted By:

Date:

7/17/2024

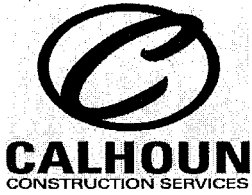

CHANGE ORDER REQUEST

Project: 638- CCS Interiors - Bernheim MS

To: Tonya Lyons
 Calhoun Construction
 7707 National Turnpike #400
 Louisville, KY 40214

From: John Wallace
 CALHOUN CONSTRUCTION

Date: 7/9/2024
 CCS COR#: 14

Item : 1 RFP 25 add wall 200C

Description	Estimated Units	Estimated UM	Estimated Unit Cost	Estimated Cost
Project Manager	2.00	HRS	90.00	180.00
Foreman	3.00	HRS	60.00	180.00
General Laborer - MH	5.00	HRS	60.00	300.00
Int Drywall & Framing Material	469.00	SF	10.70	5,018.30
Subtotal Item 1				5,678.30

Cost Type Recap:	Mark-up	Amount
1 LABOR	10.00%	726.00
5 MATERIALS	10.00%	5,520.13
Subtotal Item		6,246.13

Negotiated Project 0.00% 0.00

Requested Total For Item 1 6,246.13



CHANGE ORDER REQUEST

Project: 638- CCS Interiors - Bernheim MS

Total Change Order Request #14

6,246.13

Approved By:

Signed: _____

Date: _____

Submitted By:

Signed: OK

Date: 07/16/2024

Lyons, Tonya

From: Lyons, Tonya
Sent: Wednesday, July 17, 2024 10:12 AM
To: Lyons, Tonya
Subject: Pricing

16ga. #4 SS pcs fab and install-\$1,369.00 plus tax if applicable

~~16ga. #4 SS pcs fab and install-\$769.00 plus tax if applicable~~ Media Center

Sent from my Verizon, Samsung Galaxy smartphone
Get [Outlook for Android](#)

REQUEST FOR PROPOSAL

PROJECT:	Bernheim Middle School Renovation Shepherdsville, KY	REQUEST FOR PROPOSAL NO.:	25
OWNER:	Bullitt County Public Schools 1040 Highway 44 East Shepherdsville, KY 40165	DATE:	3-Jul-2024
TO CONTRACTOR:	Calhoun Construction Services, Inc. 7707 National Turnpike Louisville, KY 40218	ARCHITECT:	Studio Kremer Architects 1231 S Shelby Street Louisville, KY 40203
		ARCHITECT'S PROJECT NO.:	2022-36 BG# 23-051

Please submit an itemized quotation for changes in the Contract Sum and/or Time incidental to proposed modifications to the Contract Documents described herein.

THIS IS NOT A CHANGE ORDER NOR A DIRECTION TO PROCEED WITH THE WORK DESCRIBED HEREIN

Description:

Provide price proposal for the following:

Item 1:

REFERENCE ASK-15.1-15.2 AND A5.11

- Break metal to wall corners in areas bubbled on the plan (refer to ASK-15.1).
- 1 5/8" stud frame furring added to CMU walls in Alcove 200C with 5/8" gyp. (refer to ASK-15.1).
- Refer to wall sections on ASK-15.2 to see how wall is finished at clearstory.
- Storefront AA has been modified due to wall furring placement. (refer to ASK-15.2)

Attachments:

PDF: ASK-14

ISSUED:	3-Jul-2024	ARCHITECT:	studio kremer architects
CONTRACTOR:	Calhoun Construction Services, Inc.	BY:	Stephanie Satterfield

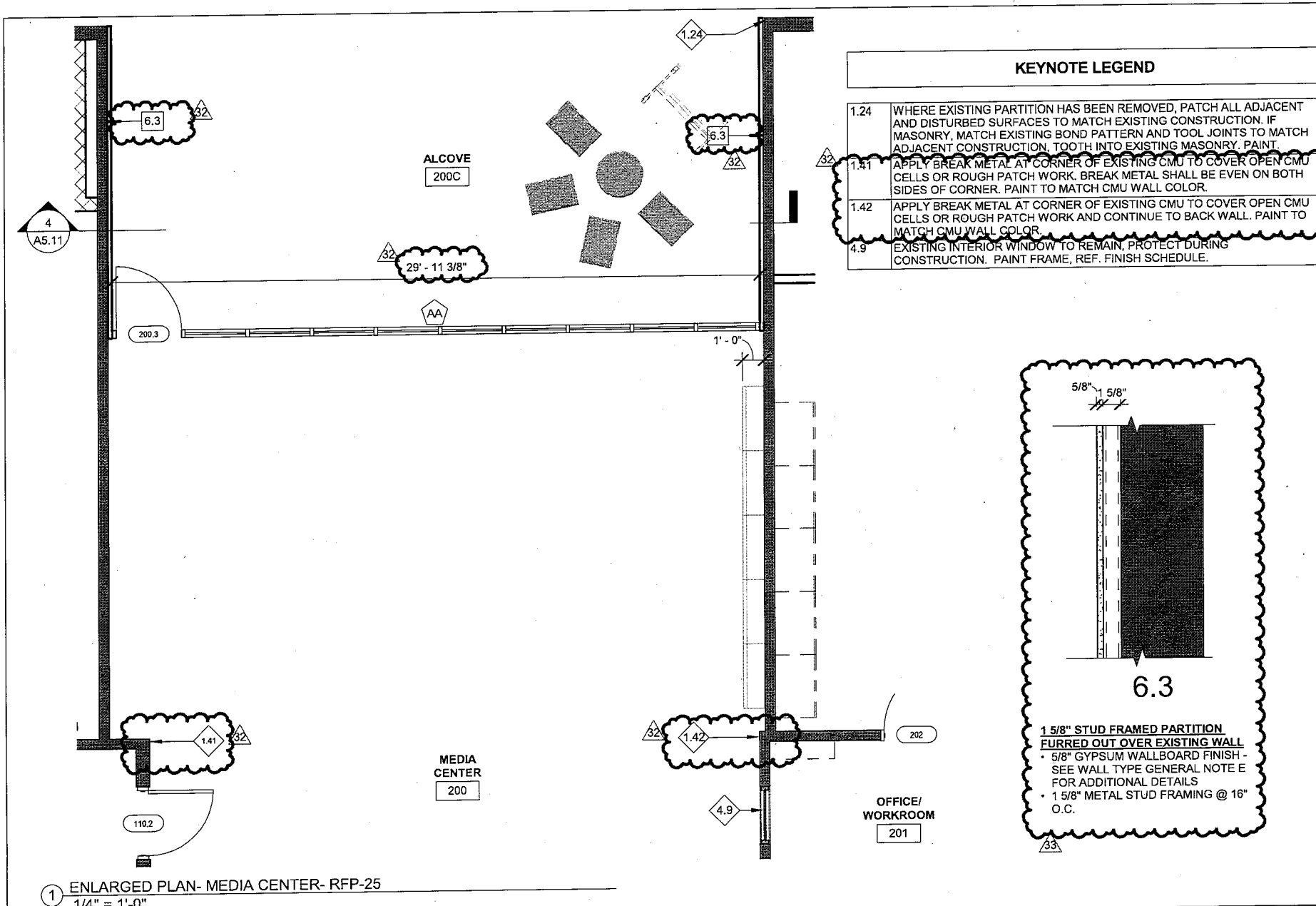

KEYNOTE LEGEND

1.24	WHERE EXISTING PARTITION HAS BEEN REMOVED, PATCH ALL ADJACENT AND DISTURBED SURFACES TO MATCH EXISTING CONSTRUCTION. IF MASONRY, MATCH EXISTING BOND PATTERN AND TOOL JOINTS TO MATCH ADJACENT CONSTRUCTION. TOOTH INTO EXISTING MASONRY. PAINT.
1.41	APPLY BREAK METAL AT CORNER OF EXISTING CMU TO COVER OPEN CMU CELLS OR ROUGH PATCH WORK. BREAK METAL SHALL BE EVEN ON BOTH SIDES OF CORNER. PAINT TO MATCH CMU WALL COLOR.
1.42	APPLY BREAK METAL AT CORNER OF EXISTING CMU TO COVER OPEN CMU CELLS OR ROUGH PATCH WORK AND CONTINUE TO BACK WALL. PAINT TO MATCH CMU WALL COLOR.
4.9	EXISTING INTERIOR WINDOW TO REMAIN, PROTECT DURING CONSTRUCTION. PAINT FRAME, REF. FINISH SCHEDULE.

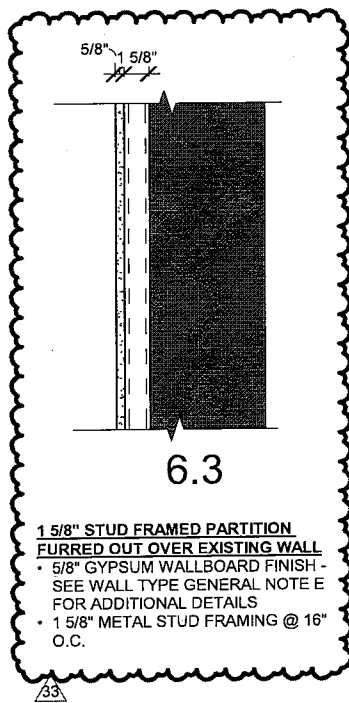

1 ENLARGED PLAN- MEDIA CENTER- RFP-25
1/4" = 1'-0"

studio kremer architects
1231 S Shelby St, Louisville, KY 40203
502.499.1100 fax 502.499.1100
S T U D I O

BULLITT COUNTY PUBLIC SCHOOLS
BERNHEIM MIDDLE SCHOOL RENOVATION
700 Audubon Drive

RFP-25
Media Center- CMU FURRING

Project no.:	2022-39	Sketch no.:	
date:	07/09/2024	drawn by:	SBS
checked by:	SVA	reference dwg.:	A0.1, A5.4
scale:	As Indicated		

ASK-15.1
7/9/2024 2:17:50 PM

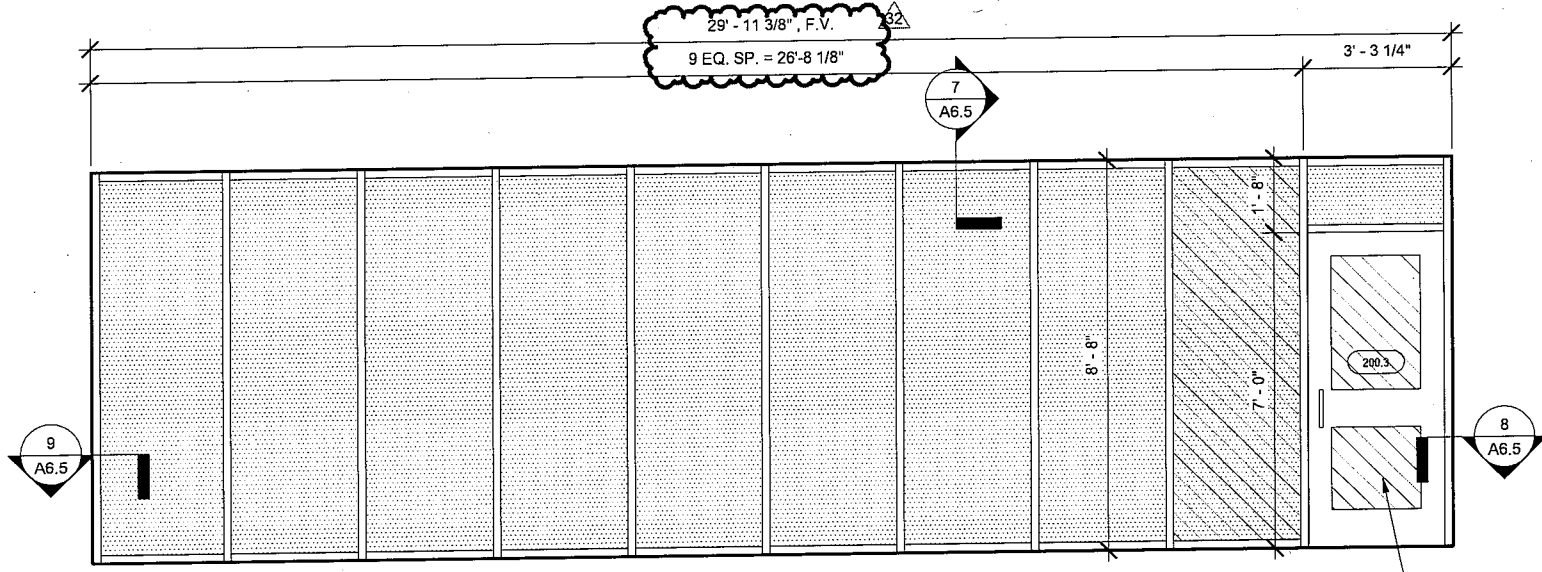

AA
ALUMINUM STOREFRONT SYSTEM

PROVIDE BORROWED
LITE ROLL DOWN
PRIVACY SHADES AT
BOTH GLASS LITES THIS
DOOR

 studio kremer architects 1231 S Shelby St, Louisville, KY 40203 502.498.1100 fax 502.498.1100 STUDIO	
BULLITT COUNTY PUBLIC SCHOOLS BERNHAIM MIDDLE SCHOOL RENOVATION 700 Audubon Drive	
title / description: MEDIA CENTER- SF MODIFICATION	project no.: 2022-06 date: 07/03/2024 drawn by: SBS checked by: SJA scale: 3/8" = 1'-0" reference dwn: A6.7
ASK-15.2	
7/3/2024 2:17:50 PM	



BRIDGE LEARNING ARCHITECTS
 1201 E. SHAW BL. CANTON, NY 14020
 TEL: 505.450.1100 FAX: 505.450.1101



INTEGRATED BID SET
 THIS DOCUMENT HAS BEEN PREPARED FOR CONSTRUCTION USE ONLY. CONSTRUCTION USE OF THIS DOCUMENT DOES NOT RELIEVE CONTRACTORS FROM THEIR RESPONSIBILITY TO NEVER, IN ANY SITUATION, PERFORM WORK BASED ON ADDENDA NO. 1, 2, 3.



ENLARGED PLAN & SECTIONS - ROOF MONITORS AT FLEX AREAS
 BERNHEIM MIDDLE SCHOOL RENOVATION
 100 W. 40th Street
 NEW YORK, NY 10018

EG# 23-051
 DATE: 09/20/24
 DRAWN BY: MNG
 CHECKED BY: JMA
 REVISIONS:

2022-36

A5.11

INTEGRATED BID SET - CONSTRUCTION DOCUMENTS

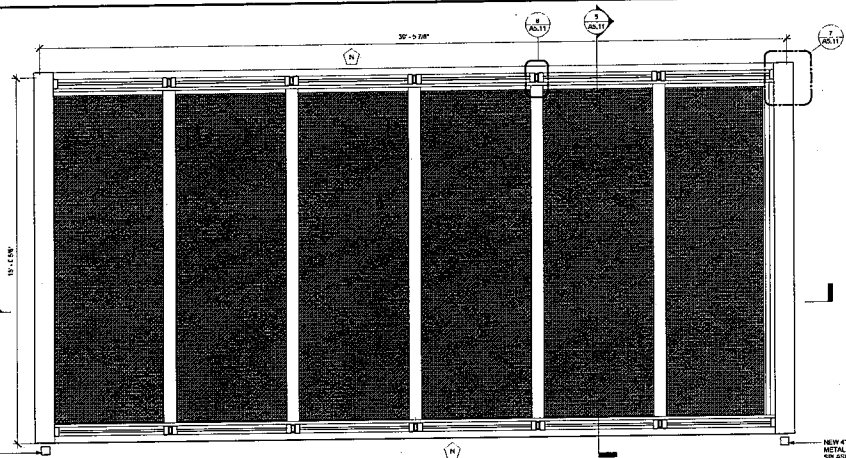

1 ENLARGED PLAN - NORTH ROOF MONITOR
 1/2" = 1'-0"

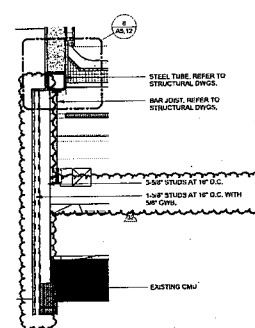

2 DETAIL - NORTH ROOF MONITOR @ WALL
 3/4" = 1'-0"

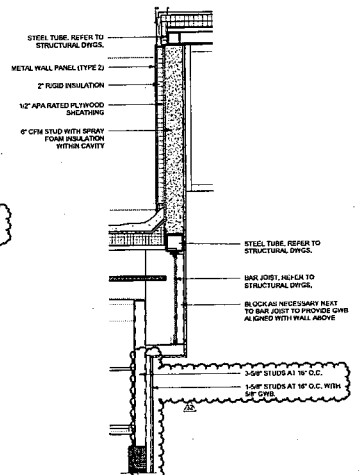

3 DETAIL - NORTH ROOF MONITOR @ ROOF
 3/4" = 1'-0"

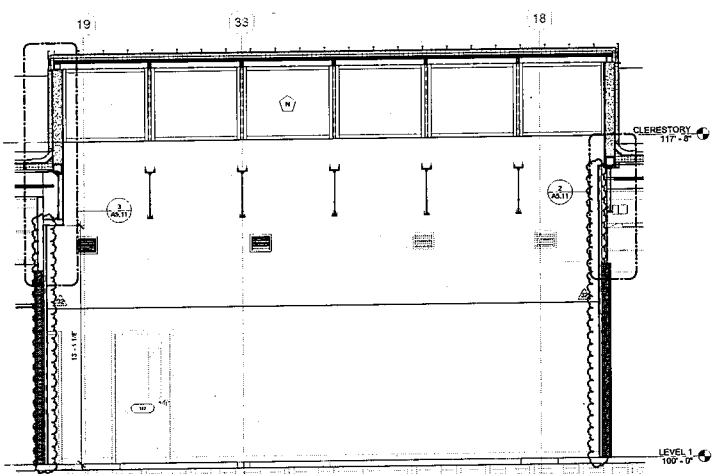

4 SECTION - NORTH MONITOR @ WALL
 3/8" = 1'-0"

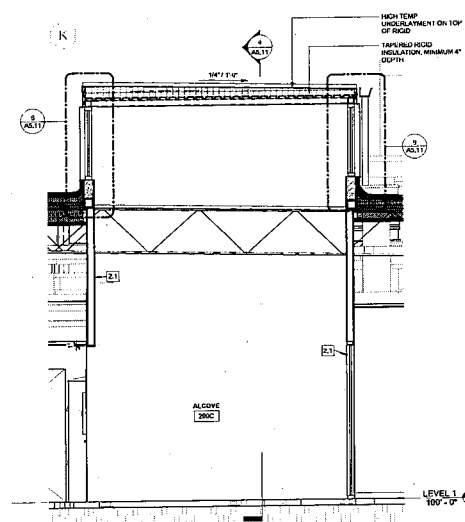

5 SECTION - NORTH MONITOR @ WINDOW
 3/8" = 1'-0"

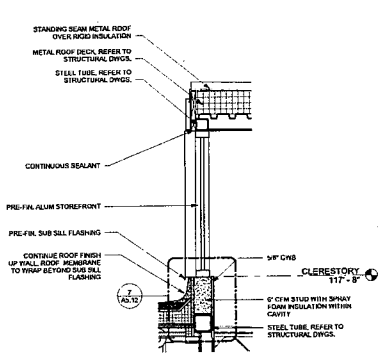

6 DETAIL - NORTH ROOF MONITOR @ WINDOW
 3/4" = 1'-0"

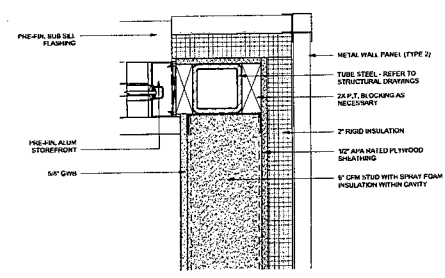

7 DETAIL - ROOF MONITOR WINDOW JAMB, CORNER
 3/4" = 1'-0"

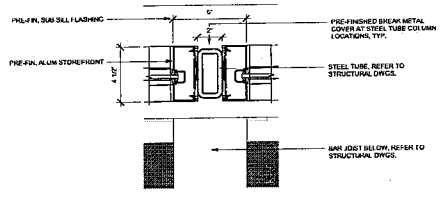

8 DETAIL - ROOF MONITOR WINDOW JAMB, TYP.
 3/4" = 1'-0"

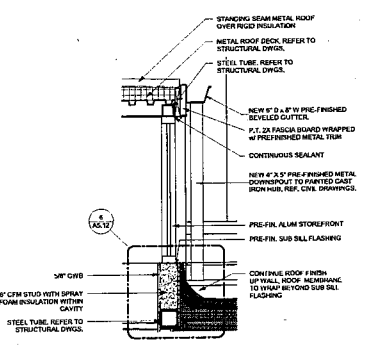

9 DETAIL - NORTH ROOF MONITOR @ WINDOW
 3/4" = 1'-0"

Change Order Request 36 - PCO #117 - Deduct for Ceiling Tile

622-Bernheim Middle School Renovation

8/5/2024



Summary of Work

Deduct for ceiling tile

Scope - Subcontractor	Description of Scope	Cost
1 Bernheim Middle School Renovation		(\$8,940.00)
1.1 Int Drywall & Framing Material - CCS Interiors -	Deduct for ceiling tile	(\$8,940.00)
		(\$8,940.00)
Total Amount		(\$8,940.00)

Approved By:

Date:

Submitted By:

Handwritten signature of Janya G. Lyons in black ink.

Date:

8/5/2024

Lyons, Tonya

From: Clemens, Danny <danny.clemens@bullitt.kyschools.us>
Sent: Friday, July 26, 2024 2:47 PM
To: Cate Noble Ward
Cc: Lyons, Tonya; Pittard, Joel; Goad, Grant; Stephanie Satterfield
Subject: Re: FW: Bernheim ACT Credit - Question for BCPS

Categories: Bernheim Middle School

Let's keep the installed ceiling and receive the credit. Thanks!

On Fri, Jul 26, 2024 at 2:24 PM Cate Noble Ward <Cate@studiokremer.com> wrote:

Hello Danny,

Calhoun let me know that the wrong ceiling tile was installed in Phases 1,2 and 3 – our submittal indicated USG 2215 and USG 2210 was installed. Calhoun has since corrected this and has removed the incorrect ceiling tile and replaced it with the 2215 version submitted. Moving forward the correct specified tile will be installed. The ceiling submittal is attached for reference and snipped in the pertinent spec information below.

The Question for you – The 2210 specification for the ACT meets Class A non-combustible requirements for a school facility. The difference between the 2210 and 2215 is the fire rating, a fire rating for general ceiling is not required, but Class A is. I do not see a life safety issue with keeping the 2210 installed in previously completed areas, and this will yield a \$8,940 credit back to the project. **Question: does BCPS want Calhoun to install USG 2215 ACT in the entire school – or – would the preference to keep the 2210 ceiling tile that is already installed and receive a \$8,940 credit?**

Cate Noble Ward, AIA, LEED AP

Architect | Partner

studio kremer architects



1231 S Shelby St, Louisville KY 40203

TEL 502.499.1100 x2583

FAX 502.499.1101

studiokremer.com

Radars™ ClimaPlus™

To:
-
-
T

UL Classified

	Edge	Panel Size Imperial Metric: (mm) ³	Class ⁴	Item No. Imperial Metric	NRC	CAC Min.	LR ⁵
30 Year System Warranty - No visible sag - Mold/mildew protection							
	RADAR CLIMAPLUS Panels	<u>2'x2'x5/8"</u>	Class A	<u>2210</u>	.55	33	.84
		2'x2'x5/8"		2210	.55	33	.84

From: Lyons, Tonya <TonyaLyons@calhounconstructs.com>
Sent: Thursday, July 25, 2024 9:44 AM
To: Cate Noble Ward <Cate@studiokremer.com>
Cc: Pittard, Joel <joelpittard@calhounconstructs.com>
Subject: Bernheim ACT Credit

Hi Cate,

Following up to our conversation yesterday, we can offer a credit of -\$8,940 if they decide to leave the installed ACT in place. If not, we can switch out all ACT 2210 for the 2215 spec. They estimate they can do that in 3 days. Going forward, we are installing the 2215 specified ACT as well as provide the attic stock with 2215 tiles.

Please let us know how we should proceed.