

AIA Document G731™ – 2019

Change Order, Construction Manager as Adviser Edition

PROJECT: <i>(name and address)</i> Central Hardin High School Addn/Renov Cecilia, KY OWNER: <i>(name and address)</i> Hardin County Board of Education 65 W A Jenkins Road Elizabethtown, KY 42701	CONTRACT INFORMATION: Contract For: BP 030-07 General Trades Date: July 14, 2021 ARCHITECT: <i>(name and address)</i> JRA Architects 3225 Summit Square Place, Suite 200 Lexington, KY 40509	CHANGE ORDER INFORMATION: Change Order Number: 086 Date: November 8, 2023 CONSTRUCTION MANAGER: <i>(name and address)</i> Alliance Corporation 116 E. College Street Glasgow, KY 42141
CONTRACTOR: <i>(name and address)</i> Alliance Corporatoin P. O. Box 1480 Glasgow, KY 42142-1480		

THE CONTRACT IS CHANGED AS FOLLOWS:

(Insert a detailed description of the change and, if applicable, attach or reference specific exhibits. Also include agreed upon adjustments attributable to executed Construction Change Directives.)

Costs associated with obtaining engineering judgement for fire resistant rated wall to wall joints and expansion joints at Area A lobby windows.

The original Contract Sum was	\$ 2,446,230.00
Net change by previously authorized Change Orders	\$ 41,127.32
The Contract Sum prior to this Change Order was	\$ 2,487,357.32
The Contract Sum will be increased by this Change Order in the amount of	\$ 8,012.95
The new Contract Sum including this Change Order will be	\$ 2,495,370.27

The Contract Time will be unchanged by Zero (0) days.
The Contractor's Work shall be substantially complete on

NOTE: This Change Order does not include adjustments to the Contract Sum or Guaranteed Maximum Price, or the Contract Time, that have been authorized by Construction Change Directive until the cost and time have been agreed upon by both the Owner and Contractor, in which case a Change Order is executed to supersede the Construction Change Directive.

NOT VALID UNTIL SIGNED BY THE ARCHITECT, CONSTRUCTION MANAGER, CONTRACTOR, AND OWNER.

JRA Architects ARCHITECT <i>(Firm name)</i>	Alliance Corporation CONSTRUCTION MANAGER <i>(Firm name)</i>
SIGNATURE D. Robert Deal, President PRINTED NAME AND TITLE	SIGNATURE Ryan Martin, Senior Project Manager PRINTED NAME AND TITLE
DATE:	DATE:
Alliance Corporatoin CONTRACTOR <i>(Firm name)</i>	Hardin County Board of Education OWNER <i>(Firm name)</i>
SIGNATURE Jake Scott Ryan Martin PRINTED NAME AND TITLE	SIGNATURE John Stith, COO PRINTED NAME AND TITLE
DATE: 11/8/2023	DATE:



AIA Document G709 - 2018

Proposal Request

PROJECT: (name and address)
Hardin County Schools Central Hardin
High School
Elizabethtown, KY

CONTRACT INFORMATION:
Contract For: General Construction

Date: September 01, 2021

Architect's Project Number: 2019111
Proposal Request Number: 038

Proposal Request Date: 12-23-2022

OWNER: (name and address)
Hardin County Board of Education

ARCHITECT: (name and address)
JRA, Inc

CONTRACTOR: (name and address)
Alliance Corporation
116 E. College Street
Glasgow, KY 42141

65 W. A. Jenkins Rd.
Elizabethtown, KY 427010

3225 summit Square Place Ste. 200
Lexington, KY 40509

The Owner requests an itemized proposal for changes to the Contract Sum and Contract Time for proposed modifications to the Contract Documents described herein. The Contractor shall submit this proposal within Zero (0) days or notify the Architect in writing of the anticipated date of submission.

(Insert a detailed description of the proposed modifications to the Contract Documents and, if applicable, attach or reference specific exhibits.)

Areas A and B are two-stories high along the west side of the existing gym with a mechanical platform acting as a mezzanine above the Sub Level Area A and First Level Area B. The KBC requires that penetrations such as chases, and stair enclosures have a 1-hour fire resistive rating when they penetrate less than three floors. The wall along the gym acts as a chase running from the Gym Level to the mechanical platform. To separate the Sub Level and First Level from the Gym Level, the wall adjoining the existing gym wall provides the required separation. This separation occurs with the CMU wall from the Sub Level Area A and First Level Area B to the bottom of the platform and is capped with the water stop detail (Detail E-A-312) at the east edge of the mechanical platform. A fire resistive expansion joint is shown on the drawings as a part of this detail but was not included in the expansion joint submittal. This detail runs the entire length of the platform in Area A and continues in Area B to the southwest corner of the exterior wall of the gym. No expansion joint "cover" is required for this joint. The non-rated expansion joints at the Sub Level door and window openings into the gym must be upgraded to fire resistant rated expansion joints.

To achieve the required separation, the following conditions must be met:

The door and window openings (See PR for added windows and expansion joints) into the gym on the Sub Level Area A must have expansion joints that have fire resistant rating. To achieve this, the fire-resistant joint system must be added to the expansion joints already shown at the heads, jambs and sills of the windows and doors.

The contractor and supplier need to review the fire-resistant rated joint at the water stop detail on the platform (Detail E-A-312) to ensure that the variations in the width of the joint caused by the irregular conditions between the gym wall and the water stop can be met with the fire resistant rated joint material. Obtain an engineering judgement if necessary.

A fire-resistant rated wall to wall joint must be added in the 2" wide expansion joint between Area A and Area B from the First Level up to the water stop detail on the mechanical platform. Since this is concealed in the double wall construction, no expansion joint cover is required.

THIS IS NOT A CHANGE ORDER, A CONSTRUCTION CHANGE DIRECTIVE, OR A DIRECTION TO PROCEED WITH THE WORK DESCRIBED IN THE PROPOSED MODIFICATIONS.

REQUESTED BY THE ARCHITECT:

D. Robert Deal, AIA, President
PRINTED NAME AND TITLE

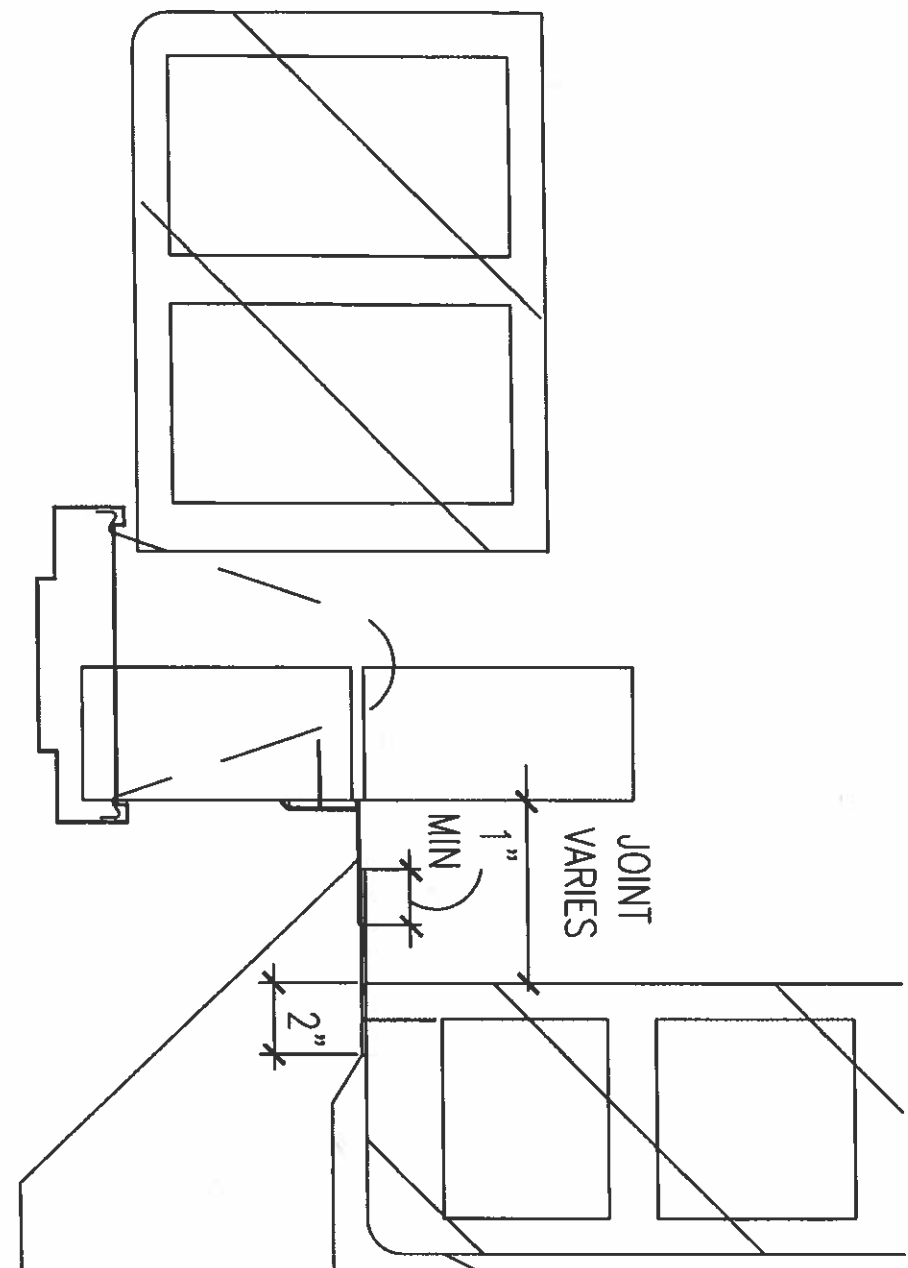

JOINT
VARIES

GROUND FACED
CMU

5" WIDE ALUM PL
VERIFY WIDTH
SECURE TO CMU W/
SS CNTSK SCREWS INTO
PLASTIC EXP ANCHORS
@ 2'-0" O.C.

ALUM EXP JNT

ALUM EXP JNT REV

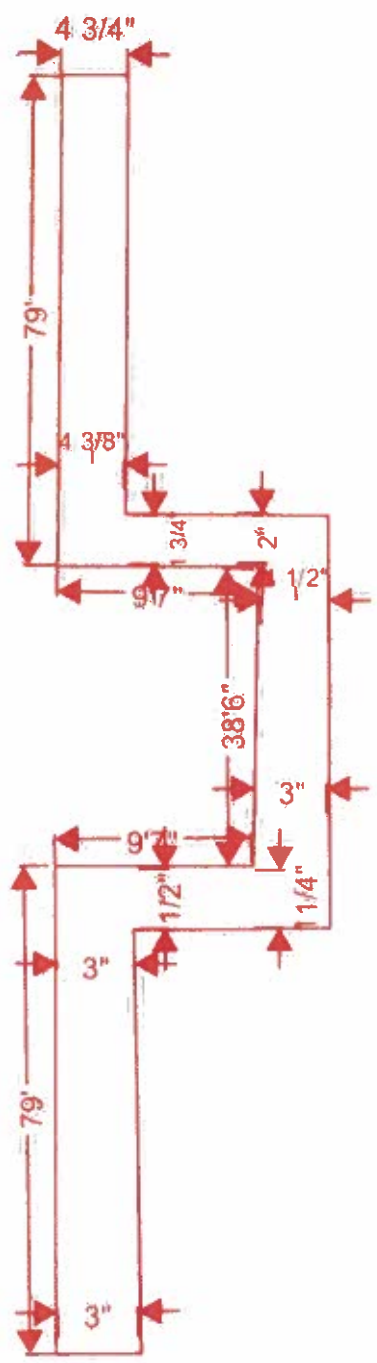

ENGINEERING JUDGMENT FIRESTOP DETAIL

THIS ENGINEERING JUDGMENT REPRESENTS A FIRESTOP SYSTEM THAT WOULD BE EXPECTED TO PASS THE STATED RATINGS IF TESTED

PROJECT : CENTRAL HARDIN HIGH SCHOOL
 ADDRESS : 3040 LEITCHFIELD RD, CECILIA, KENTUCKY 42724

ISSUED TO : ALLIANCE CORPORATION

Ratings

F-RATING = 2-HR.

CROSS-SECTIONAL VIEW

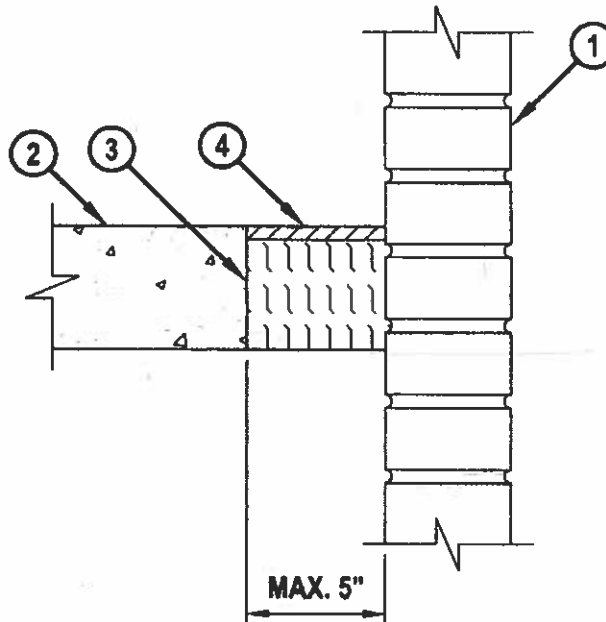

1. CONCRETE WALL ASSEMBLY TO BE ONE OF THE FOLLOWING (2-HR. FIRE-RATING) :
 - A. LIGHTWEIGHT OR NORMAL WEIGHT CONCRETE WALL (MINIMUM 4-1/2" THICK).
 - B. ANY UL/cUL CLASSIFIED CONCRETE BLOCK WALL (MIN. 4-1/2" THICK) (SOLID OR GROUT FILLED).
 - C. LIGHTWEIGHT OR NORMAL WEIGHT BRICK WALL (MIN. 4-1/2" THICK) (SOLID OR GROUT FILLED).
2. LIGHTWEIGHT OR NORMAL WEIGHT CONCRETE FLOOR (MINIMUM 4-1/2" THICK) (2-HR. FIRE-RATING).
3. MINIMUM 4" THICKNESS MINERAL WOOL SAFING (MIN. 4 PCF DENSITY) COMPRESSED 50%.
4. MINIMUM 1/2" DEPTH HILTI CFS-S SIL GG FIRESTOP SILICONE SEALANT OR HILTI CFS-S SIL SL FIRESTOP SILICONE SEALANT.

NOTES : 1. MAXIMUM WIDTH OF JOINT = 5".
 2. T-RATING MAY NOT EQUAL F-RATING IN ACCORDANCE WITH APPLICABLE TEST METHOD.

Referenced Tested Systems
 (REFERENCE : UL/cUL SYSTEM NO. FW-D-1037)

Project Application Details
 CS0176233
 Applicable Test Method
 UL 2079



HILTI, Inc.
 Plano, Texas USA (800) 879-8000
 Designed by Hilti FPE
 Kevin Riechers *Kevin Riechers*
 Drafter
 DS

Sheet 1 of 1
 Scale 5/32" = 1"
 Date July 14, 2023

Drawing No.
600372a

Saving Lives through Innovation and Education

ENGINEERING JUDGMENT FIRESTOP DETAIL

THIS ENGINEERING JUDGMENT REPRESENTS A FIRESTOP SYSTEM THAT WOULD BE EXPECTED TO PASS THE STATED RATINGS IF TESTED

PROJECT : CENTRAL HARDIN HIGH SCHOOL
ADDRESS : 3040 LEITCHFIELD RD, CECILIA, KENTUCKY 42724

ISSUED TO : ALLIANCE CORPORATION

Ratings

F-RATING = 2-HR. (SEE NOTE NO. 2 BELOW)

CONFIGURATION A (CROSS-SECTIONAL VIEW)

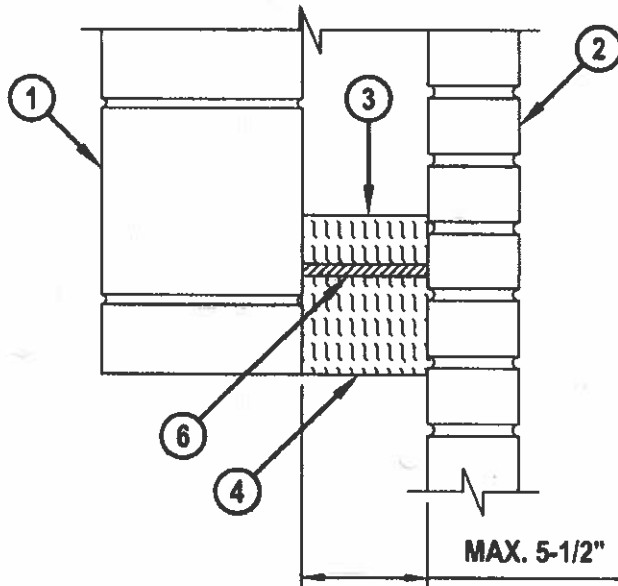

CONFIGURATION B (TOP VIEW)

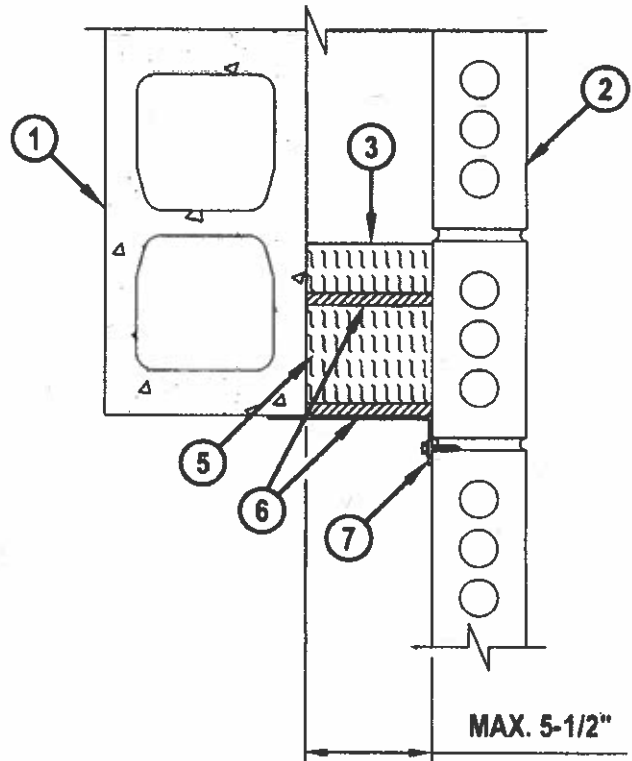

HILTI, Inc.
Plano, Texas USA (800) 879-8000
Designed by Hilti FPE
Kevin Riechers *Kevin Riechers*
Drafter **AN**

Sheet 1 of 2
Scale 9/64" = 1"
Date July 14, 2023

Drawing No.
600405a

Saving Lives through Innovation and Education



UNIVERSAL FIRESTOP SERVICES

Po Box 527, Simpsonville Ky 40067

Office 502-265-0246

July 19, 2023

Brandon,

The following is for the proper installation of UL approved firestop systems for the Central Hardin project in Cecilia KY. The below price includes firestopping of approx. 215 l/ft of edge of slab to brick wall. Please call with any questions!

Total \$5,760

Jason Hines

Senior Project Manager

Universal Firestop Services

Cell 502-773-3884

Accepted

BRANDON AKOFS

7/19/23



UNIVERSAL FIRESTOP SERVICES
Po Box 527, Simpsonville Ky 40067

Office 502-265-0246

August 3, 2023

Brandon,

The following is for the proper installation of UL approved firestop systems for the Central Hardin project in Cecilia KY. The below price includes firestopping of two windows and two doors.

1. Doors is a 2" joint around the sides and head. Total footage is aprox 50' \$550.00
2. Windows is a 5-1/2" joint around the sides and head. Total footage is aprox 40' 650.00

Total \$1,200.00

Jason Hines

Senior Project Manager

Universal Firestop Services

Cell 502-773-3884

FACPAC Contract Change Order Supplemental Information Form (Ref# 58947)

Form Status: Saved

Tier 1 Project: CHHS Renovation Phase 1

BG Number: 20-136

Status: Active

District: Hardin County (HB678)

Phase: Project Initiation (View Checklist)

Contract: Alliance Corporation, 0030, General Trades

Type: CM Bid Package

Proposed

Change Order Number	7
Time Extension Required	No
Date Of Change Order	11/8/2023
Change Order Amount To Date	Increase

Construction Contingency

Calculations below are project wide. Remaining negative Construction Contingency may require the submission of a revised BG1.

Current Approved Amount	\$3,254,314.84
Net Approved COs	\$171,553.09
Remaining After Approved COs	\$3,082,761.75
Net All COs	\$207,179.99
Remaining After All COs	\$3,047,134.85

This Requested Change Order Amount \$8,012.95

+/-

Change In A/E Fee This Change Order

+/-

Change In CM Fee This Change Order \$0.00

+/-

Remaining Construction Contingency \$3,047,134.85

Balance

Contract Change Requested By Architect/Engineer

Contract Change Reason Code Expansion of Scope

Change Order Description And Justification

Costs associated with obtaining engineering judgement for fire resistant rated wall to wall joints and expansion joints at Area A lobby windows.

Cost Benefit To Owner

The cost of this change order has been reviewed and determined to be reasonable.

Contract unit prices have been utilized No

to support the cost associated with this change order.

Detailed Cost Breakdown

Contract unit prices have not been utilized, provide a detailed cost breakdown which separates labor, material, profit and overhead.

Detail Item	Amount	Percent of Total
Labor	\$7,419.39	92.59%
Materials		0.00%
Profit and Overhead	\$370.98	4.63%
Bond Insurance	\$222.58	2.78%
Cost Breakdown Total:	\$8,012.95	

Cost for this Change Order supported by an alternate bid or competitive price quote No

Explain Why Executed contract with contractor.

**Change Order Supplemental Information Form Signature
Page (Online Form Ref# 58947)**

Architect

Date

Construction Manager

Date

Finance Officer

Date

Local Board of Education Designee

Date