

DANNY CLEMENS, DIRECTOR
GEORGE BROCK, MAINTENANCE SUPERVISOR
THOMAS STOKES, CUSTODIAL SUPERVISOR
ANDREA ROCK, ENERGY MANAGER

DEPARTMENT OF FACILITIES

MEMO

TO: Dr. Jesse Bacon, Superintendent
FROM: Danny Clemens, Director of Facilities
Date: November 15, 2023
RE: Change Order #03 – BMS Window and Storefront Trim **DC**

After demolition had commenced at new window openings in existing walls, it was determined additional metal trim would be required to improve the jamb appearance at the enlarged classroom windows. Metal trim matching the window frames is being added at all Window types "A". Also, a new brick sill is being added to the Enlarged windows at the Art Room. In addition to improvements at the exterior windows, the interior glass storefront systems sills are being raised from 2-inches high to 4-inches high to raise that glazing along the floor line. This incurred additional material costs. See COR's 7 and 8 for cost break-outs.

I recommend approval of this request.

Attachment:

- G701-2017 - Change Order 3 - BMS Window and Storefront Trim - *For Signature*
- CO 3 - FACPAC - Window and Storefront Trim - *For Signature*
- COR-7 RFP-5 + Glazing Details – *No action, for Reference*
- COR-8 RFP-6 Break Metal Column Wrap – *No action, for Reference*

OUR MISSION IS TO INSPIRE AND EQUIP OUR STUDENTS TO SUCCEED IN LIFE

BULLITT COUNTY PUBLIC SCHOOLS IS AN EQUAL EDUCATION AND EMPLOYMENT INSTITUTION



AIA® Document G701® – 2017

Change Order

PROJECT: *(Name and address)*
Bernheim Middle School Renovation
700 Audubon Drive, Shepherdsville, KY
40165

CONTRACT INFORMATION:
Contract For: General Construction
Date: June 19, 2023

CHANGE ORDER INFORMATION:
Change Order Number: 003
Date: November 27, 2023

OWNER: *(Name and address)*
Bullitt County Public Schools Board of
Education
1040 Hwy 44 East
Shepherdsville, KY 40165

ARCHITECT: *(Name and address)*
Studio Kremer Architects, Inc.
1231 S. Shelby Street
Louisville, KY 40203

CONTRACTOR: *(Name and address)*
Calhoun Construction Services, Inc.
7707 National Turnpike
Louisville, Kentucky 40218

THE CONTRACT IS CHANGED AS FOLLOWS:

(Insert a detailed description of the change and, if applicable, attach or reference specific exhibits. Also include agreed upon adjustments attributable to executed Construction Change Directives.)

See COR's #7 & #8 and RFP #05 and #06 for scope of Work included in this Change Order.

The original Contract Sum was	\$	20,787,544.59
The net change by previously authorized Change Orders	\$	-710,889.63
The Contract Sum prior to this Change Order was	\$	20,076,654.96
The Contract Sum will be increased by this Change Order in the amount of	\$	9,157.00
The new Contract Sum including this Change Order will be	\$	20,085,811.96

The Contract Time will be unchanged by Zero (0) days.
The new date of Substantial Completion will be

NOTE: This Change Order does not include adjustments to the Contract Sum or Guaranteed Maximum Price, or the Contract Time, that have been authorized by Construction Change Directive until the cost and time have been agreed upon by both the Owner and Contractor, in which case a Change Order is executed to supersede the Construction Change Directive.

NOT VALID UNTIL SIGNED BY THE ARCHITECT, CONTRACTOR AND OWNER.

Studio Kremer Architects, Inc.

Calhoun Construction Services, Inc.

Bullitt County Public Schools Board of
Education

ARCHITECT *(Firm name)*

CONTRACTOR *(Firm name)*

OWNER *(Firm name)*

SIGNATURE

SIGNATURE

SIGNATURE

Catherine Noble Ward, AIA

Joel Pittard, Project Manager

Dr. Jesse Bacon, Superintendent

PRINTED NAME AND TITLE

PRINTED NAME AND TITLE

PRINTED NAME AND TITLE

11-14-2023

11/13/2023

DATE

DATE

DATE

FACPAC Contract Change Order Supplemental Information Form (Ref# 58964)

Form Status: Saved

Tier 1 Project: Bernheim Middle School -Renovation

BG Number: 23-051

District: Bullitt County (HB678)

Status: Active

Phase: Project Initiation (View Checklist)

Contract: Calhoun Construction Services, Inc., 0001, General Construction

Type: General Contractor

Proposed

Change Order Number	3
Time Extension Required	No
Date Of Change Order	11/27/2023
Change Order Amount To Date	Increase

Construction Contingency

Calculations below are project wide. Remaining negative Construction Contingency may require the submission of a revised BG1.

Current Approved Amount	\$1,261,761.60
Net Approved COs	\$0.00
Remaining After Approved COs	\$1,261,761.60
Net All COs	\$-156,326.62
Remaining After All COs	\$1,418,088.22

This Requested Change Order Amount \$9,157.00

+/-

Change In A/E Fee This Change Order \$457.85

+/-

Change In CM Fee This Change Order \$0.00

+/-

Remaining Construction Contingency \$1,418,088.22

Balance

Contract Change Requested By Architect/Engineer

Contract Change Reason Code Improved Plans/Specs

Change Order Description And Justification

After demolition had commenced at new window openings in existing walls, it was determined additional metal trim would be required to improve the jamb appearance at the enlarged classroom windows. Metal trim matching the window frames is being added at all Window types "A". Also, a new brick sill is being added to the Enlarged windows at the Art Room.

In addition to improvements at the exterior windows, the interior glass storefront systems sills are being raised from 2-inches high to 4-inches high to raise that glazing along the floor line.

This incurred an additional material costs.

See COR's 7 and 8 for cost break-outs.

Cost Benefit To Owner

Work can proceed on the original schedule and phasing proceeds as originally planned.

Contract unit prices have been utilized No
to support the cost associated with this
change order.

Detailed Cost Breakdown

Contract unit prices have not been utilized, provide a detailed cost breakdown which separates labor, material, profit and overhead.

Detail Item	Amount	Percent of Total
Labor		0.00%
Materials	\$8,242.00	90.01%
Profit and Overhead	\$825.00	9.01%
Bond Insurance	\$90.00	0.98%
Cost Breakdown Total:	\$9,157.00	

Cost for this Change Order supported No
by an alternate bid or competitive price
quote

Explain Why

Work can commence with trades already on site and avoid the added cost of mobilization and general conditions.

**Change Order Supplemental Information Form Signature
Page (Online Form Ref# 58964)**

Catherine N. Ward
Architect

11-14-2023

Date

N/A

Construction Manager

Date

Lisa Lewis

Finance Officer

11-20-23

Date

Local Board of Education Designee

Date



Change Order Request 7 - PCO #21 - RFP-5 Aluminum Windows and Brick Sill

622-Bernheim Middle School Renovation

10/31/2023



Summary of Work

RFP-5 Aluminum Window Sill at New Brick Sill + added Details per reviewed Glass Shop Drawings

Scope - Subcontractor	Description of Scope	Cost
1 Bernheim Middle School		\$7,852.00
1.1 Unit Masonry - McDuffie	New brick window sills	\$2,552.00
2.1 Glazing & Storefronts - Stanley Schultze	Add dark bronze break metal to windows; Add Details A&B per reviewed shop drawings	\$5,300
		\$7,852.00
	Fee 10.00%	\$785
	Bond 1.00%	\$86
Total Amount		\$8,724

Approved By:

Submitted By:

Date:

Date:

10/31/2023

Lyons, Tonya

To: Kevin Alford
Subject: RE: FW: BMS - Brick Sill Match RFP-5 Pricing

Thanks,

Tonya Lyons

Project Engineer

CALHOUN CONSTRUCTION

7707 National Turnpike, Suite 400

Louisville, KY 40214

Office (502)493-1332

Cell (770)241-9227



From: Kevin Alford <alford.mcduffieconstruction@gmail.com>

Sent: Tuesday, October 31, 2023 9:11 AM

To: Lyons, Tonya <TonyaLyons@calhounconstructs.com>

Subject: Re: FW: BMS - Brick Sill Match RFP-5 Pricing

Tonya, our price for RFP#5 is \$2,551.59. The brick can only be ordered from the manufacturer in cube sizes.

Thanks,
Kevin

On Mon, Oct 30, 2023 at 1:01 PM Lyons, Tonya <TonyaLyons@calhounconstructs.com> wrote:

What's the status of this pricing?

Tonya Lyons

Project Engineer

CALHOUN CONSTRUCTION

7707 National Turnpike, Suite 400

Louisville, KY 40214

Office (502)493-1332

Cell (770)241-9227



From: Kevin Alford <alford.mcduffieconstruction@gmail.com>
Sent: Thursday, October 26, 2023 3:23 PM
To: Lyons, Tonya <TonyaLyons@calhounconstructs.com>
Subject: Re: FW: BMS - Brick Sill Match RFP-5 Pricing

Tonya, will do .

Thanks

On Thu, Oct 26, 2023 at 12:54 PM Lyons, Tonya <TonyaLyons@calhounconstructs.com> wrote:

Kevin... the architect has approved the brick sample presented (see below). Please provide pricing for this RFP-5 ASAP.

Thank,

Tonya Lyons

Project Engineer

CALHOUN CONSTRUCTION

7707 National Turnpike, Suite 400

Louisville, KY 40214

Office (502)493-1332

Cell (770)241-9227



From: Stephanie Satterfield <stephanie@studiokremer.com>
Sent: Thursday, October 26, 2023 1:42 PM
To: Lyons, Tonya <TonyaLyons@calhounconstructs.com>
Cc: Pittard, Joel <joelpittard@calhounconstructs.com>; Thompson, Laney <LaneyThompson@calhounconstructs.com>
Subject: RE: BMS - Brick Sill Match?

Tonya,

Yes, we can move forward with this brick.

Stephanie Satterfield, Assoc. AIA

Architectural Designer

studio **kremer** architects



1231 S Shelby St, Louisville KY 40203

TEL 502.499.1100 x2525

FAX 502.499.1101

studiokremer.com

From: Lyons, Tonya <TonyaLyons@calhounconstructs.com>
Sent: Thursday, October 26, 2023 1:35 PM
To: Stephanie Satterfield <stephanie@studiokremer.com>
Cc: Pittard, Joel <joelpittard@calhounconstructs.com>; Thompson, Laney <LaneyThompson@calhounconstructs.com>
Subject: BMS - Brick Sill Match?

Hi Stephanie,

Lyons, Tonya

From: Cate Noble Ward <Cate@studiokremer.com>
Sent: Wednesday, October 18, 2023 10:39 AM
To: Lyons, Tonya; Stephanie Satterfield
Cc: Pittard, Joel
Subject: RE: Bernheim MS- Window and Storefront RESUBMIT Shop Drawing

Categories: Bernheim Pricing

Tonya,

Please proceed with providing a COR for the added scope for the Sill Height Revisions at the Interior and Exterior Storefront.

Thanks,
Cate

Cate Noble Ward, AIA, LEED AP
Architect | Partner



studio kremer architects
1231 S Shelby St, Louisville KY 40203
TEL 502.499.1100 x2583
FAX 502.499.1101
studiokremer.com

From: Lyons, Tonya <TonyaLyons@calhounconstructs.com>
Sent: Wednesday, October 18, 2023 9:32 AM
To: Stephanie Satterfield <stephanie@studiokremer.com>
Cc: Pittard, Joel <joelpittard@calhounconstructs.com>; Cate Noble Ward <Cate@studiokremer.com>
Subject: RE: Bernheim MS- Window and Storefront RESUBMIT Shop Drawing
Importance: High

Good morning... just following up on this question. Please let me know if I need to submit a COR so we can get the materials into fabrication.

Thanks,

Tonya Lyons

Project Engineer
CALHOUN CONSTRUCTION
7707 National Turnpike, Suite 400
Louisville, KY 40214
Office (502)493-1332
Cell (770)241-9227



From: Lyons, Tonya <TonyaLyons@calhounconstructs.com>
Sent: Monday, October 16, 2023 1:51 PM
To: Stephanie Satterfield <stephanie@studiokremer.com>
Cc: Pittard, Joel <joelpittard@calhounconstructs.com>; Cate Noble Ward <Cate@studiokremer.com>; Lyons, Tonya <TonyaLyons@calhounconstructs.com>
Subject: FW: Bernheim MS- Window and Storefront RESUBMIT Shop Drawing
Importance: High

Hi Stephanie,

Please see the glass contractor's note below regarding the 2 Details inserted into the shop drawing reviewed submittal (attached). The cost impact is roughly \$2,389, including OVHP. This does not impact his DPO.

Please advise if I should send the COR for processing.

Thanks,

Tonya Lyons

Project Engineer

CALHOUN CONSTRUCTION

7707 National Turnpike, Suite 400

Louisville, KY 40214

Office (502)493-1332

Cell (770)241-9227



From: Mike Bale <mbale@stanleyschultze.com>
Sent: Monday, October 16, 2023 10:24 AM
To: Thompson, Laney <LaneyThompson@calhounconstructs.com>
Cc: Goad, Grant <grantgoad@calhounconstructs.com>; Lyons, Tonya <TonyaLyons@calhounconstructs.com>; Pittard, Joel <joelpittard@calhounconstructs.com>
Subject: RE: Bernheim MS- Window and Storefront RESUBMIT Shop Drawing

The detail A in the exterior and Detail B on the interior submittals, that the architect added, are not on the plans anywhere.

I just want to get this going, and not sure how to approach this.

There is a definite cost difference

Lyons, Tonya

From: Mike Bale <mbale@stanleyschultze.com>
Sent: Monday, October 16, 2023 12:05 PM
To: Lyons, Tonya
Subject: RE: Bernheim Blinds

Categories: Bernheim Pricing

It was actually more than I thought it would be.
Roughly, \$2,150.00

Thank you
Michael Bale
Project Manager



849 South 6th Street
Louisville, KY 40203
502-585-4256
502-585-4496 (Fax)
502-592-7620 (Mobile)
mbale@stanleyschultze.com
www.stanleyschultze.com

From: Lyons, Tonya <TonyaLyons@calhounconstructs.com>
Sent: Monday, October 16, 2023 11:56 AM
To: Mike Bale <mbale@stanleyschultze.com>
Subject: RE: Bernheim Blinds

CAUTION: This email originated from outside of the organization. Do not click links or open attachments unless you recognize the sender and know the content is safe.

Requested. Let us know about the pricing on the Details added in the submittal so we can figure that out as well.

Thanks,

Tonya Lyons

Project Engineer
CALHOUN CONSTRUCTION
7707 National Turnpike, Suite 400
Louisville, KY 40214
Office (502)493-1332
Cell (770)241-9227

Thank you
Michael Bale
Project Manager



849 South 6th Street
Louisville, KY 40203
502-585-4256
502-585-4496 (Fax)
502-592-7620 (Mobile)
mbale@stanleyschultze.com
www.stanleyschultze.com

From: Thompson, Laney <LaneyThompson@calhounconstructs.com>
Sent: Tuesday, October 10, 2023 9:39 AM
To: Mike Bale <mbale@stanleyschultze.com>
Cc: Goad, Grant <grantgoad@calhounconstructs.com>; Lyons, Tonya <TonyaLyons@calhounconstructs.com>
Subject: FW: Bernheim MS- Window and Storefront RESUBMIT Shop Drawing

CAUTION: This email originated from outside of the organization. Do not click links or open attachments unless you recognize the sender and know the content is safe.

Mike,
See the reviewed submittal above.
Thanks!



Laney Thompson, Project Engineer Intern
Calhoun Construction Services
7707 National Turnpike #400
Louisville, KY 40214
calhounconstructs.com

From: Stephanie Satterfield <stephanie@studiokremer.com>
Sent: Tuesday, October 10, 2023 9:31 AM
To: Lyons, Tonya <TonyaLyons@calhounconstructs.com>; Thompson, Laney <LaneyThompson@calhounconstructs.com>; Dirks, Devin <DevinDirks@calhounconstructs.com>; Pittard, Joel <joelpittard@calhounconstructs.com>; Goad, Grant <grantgoad@calhounconstructs.com>
Subject: Bernheim MS- Window and Storefront RESUBMIT Shop Drawing

All,

I am having a bit of issues with Procore at the moment, but I wanted to return the Window and Storefront Submittal quickly. Once I am able to upload the submittal I will do that but in the meantime please see the attached Reviewed as Noted submittal.

Stephanie Satterfield, Assoc. AIA

Lyons, Tonya

From: Mike Bale <mbale@stanleyschultze.com>
Sent: Tuesday, October 24, 2023 10:24 AM
To: Lyons, Tonya; Kevin Alford
Cc: Pittard, Joel; Goad, Grant
Subject: RE: Bernheim MS- RFP-5

Categories: Bernheim Pricing

Tonya, to add dark bronze break metal to the windows in the existing building only, Add \$3,150.00

Thank you
Michael Bale
Project Manager



849 South 6th Street
Louisville, KY 40203
502-585-4256
502-585-4496 (Fax)
502-592-7620 (Mobile)
mbale@stanleyschultze.com
www.stanleyschultze.com

From: Lyons, Tonya <TonyaLyons@calhounconstructs.com>
Sent: Thursday, October 19, 2023 6:03 PM
To: Mike Bale <mbale@stanleyschultze.com>; Kevin Alford <alford.mcduffieconstruction@gmail.com>
Cc: Pittard, Joel <joelpittard@calhounconstructs.com>; Goad, Grant <grantgoad@calhounconstructs.com>; Lyons, Tonya <TonyaLyons@calhounconstructs.com>
Subject: FW: Bernheim MS- RFP-5

CAUTION: This email originated from outside of the organization. Do not click links or open attachments unless you recognize the sender and know the content is safe.

Guys,

I distributed the RFI response via Procore that address these changes. Please review carefully and provide pricing per the changes noted in the attached RFP-5.

Thanks,

Tonya Lyons

Project Engineer
CALHOUN CONSTRUCTION
7707 National Turnpike, Suite 400
Louisville, KY 40214

Office (502)493-1332
Cell (770)241-9227



From: Stephanie Satterfield <stephanie@studiokremer.com>

Sent: Thursday, October 19, 2023 5:35 PM

To: Goad, Grant <grantgoad@calhounconstructs.com>; Pittard, Joel <joelpittard@calhounconstructs.com>; Lyons, Tonya <TonyaLyons@calhounconstructs.com>; Thompson, Laney <LaneyThompson@calhounconstructs.com>; Dirks, Devin <DevinDirks@calhounconstructs.com>

Cc: Cate Noble Ward <Cate@studiokremer.com>

Subject: Bernheim MS- RFP-5

All,

Please provide pricing for the attached RFP-5. This addresses the issues reported in RFI#24 regarding the window jamb in Type A and E and the window sill in Type E.

Thank you,

Stephanie Satterfield, Assoc. AIA
Architectural Designer



studio kremer architects

1231 S Shelby St, Louisville KY 40203

TEL 502.499.1100 x2525

FAX 502.499.1101

studiokremer.com

REQUEST FOR PROPOSAL

PROJECT:	Bernheim Middle School Renovation Shepherdsville, KY	REQUEST FOR PROPOSAL NO.:	05
OWNER:	Bullitt County Public Schools 1040 Highway 44 East Shepherdsville, KY 40165	DATE:	19-Oct-2023
TO CONTRACTOR:	Calhoun Construction Services, Inc. 7707 National Turnpike Louisville, KY 40218	ARCHITECT:	Studio Kremer Architects 1231 S Shelby Street Louisville, KY 40203
		ARCHITECT'S PROJECT NO.:	2022-36 BG# 23-051

Please submit an itemized quotation for changes in the Contract Sum and/or Time incidental to proposed modifications to the Contract Documents described herein.

THIS IS NOT A CHANGE ORDER NOR A DIRECTION TO PROCEED WITH THE WORK DESCRIBED HEREIN

Description:

Provide price proposal for the following:

- Item 1:** REFERENCE RFP-5.1, 5.2, and 5.3 DRAWING
- Modified Window Type A and E's window jamb along the existing brick veneer wall to include break metal that matches the window frame color.
 - Modified Window Type E to provide a new brick sill.

Attachments:

PDFs: RFP-4

ISSUED:	19-Oct-2023	ARCHITECT:	studio kremer architects
CONTRACTOR:	Calhoun Construction Services, Inc.	BY:	Stephanie Satterfield

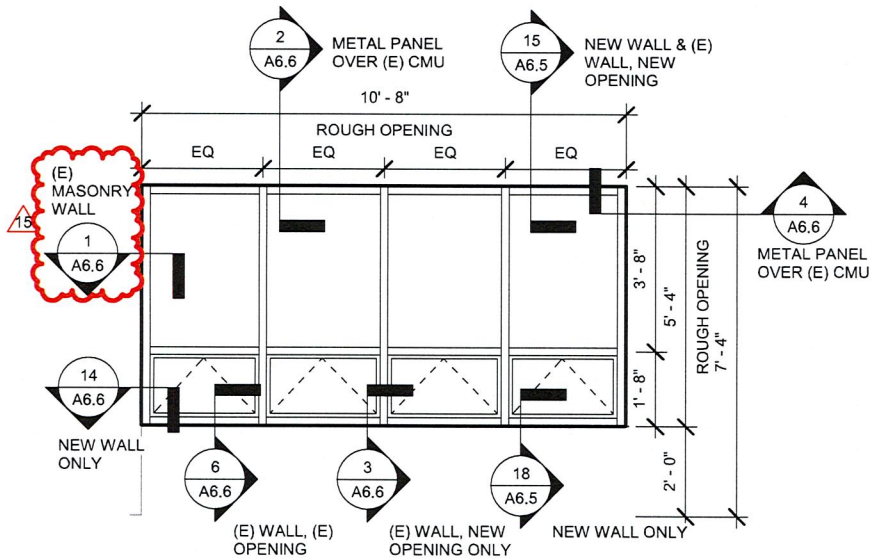

 THERMALLY BROKEN 4" DEEP ALUMINUM WINDOW W/ OPERABLE VENT - 1" INSULATED GLAZING W/ INTEGRATED BLINDS @ BOTH FIXED AND VENT GLAZING

① STOREFRONT A- RFP-5
 3/8" = 1'-0"

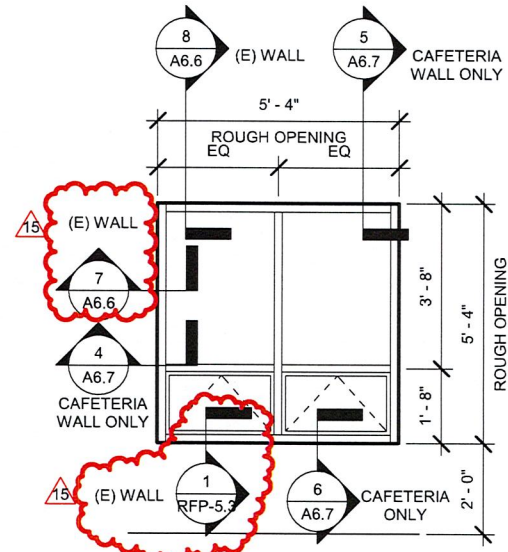

 THERMALLY BROKEN 4" DEEP ALUMINUM WINDOW W/ OPERABLE VENT - 1" INSULATED GLAZING W/ INTEGRATED BLINDS @ BOTH FIXED AND VENT GLAZING

② STOREFRONT E- RFP-5
 3/8" = 1'-0"



studio **kramer** architects
 1231 S Shelby St, Louisville, KY 40203
 502.499.1100 fax 502.499.1100

BULLITT COUNTY PUBLIC SCHOOLS
BERNHAIM MIDDLE SCHOOL RENOVATION

700 Audubon Drive

title / description:
WINDOW ELEVATIONS

project no.:	2022-38	sketch no.:	
drawn by:	10/19/2023	reference no.:	RFP-5.1
checked by:	CVA		
scale:	3/8" = 1'-0"		

10/19/2023 5:27:01 PM AS.2

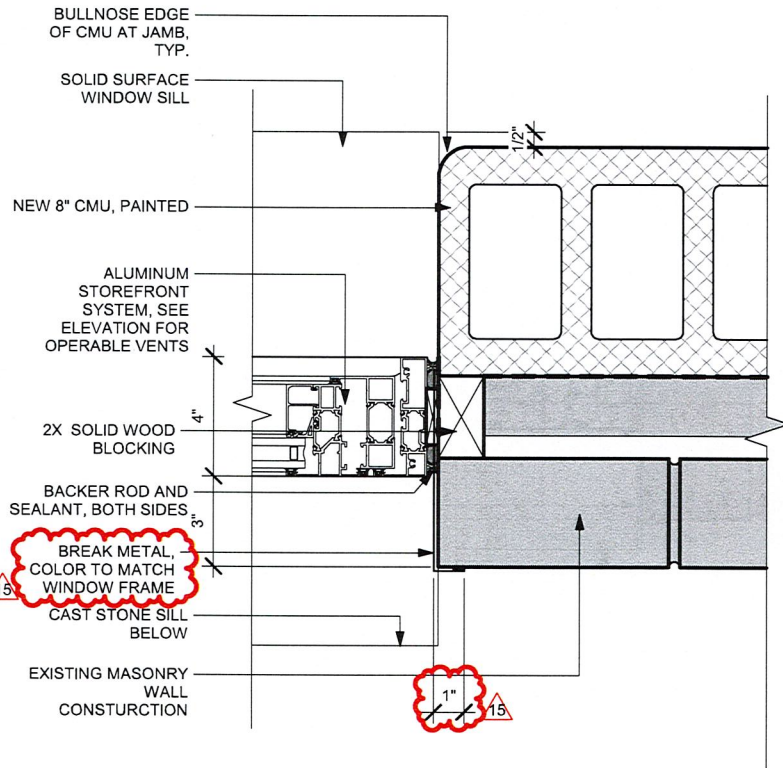

① ALUMINUM WINDOW JAMB @ (E) WALL- NEW OPENING- RFP-5
3" = 1'-0"

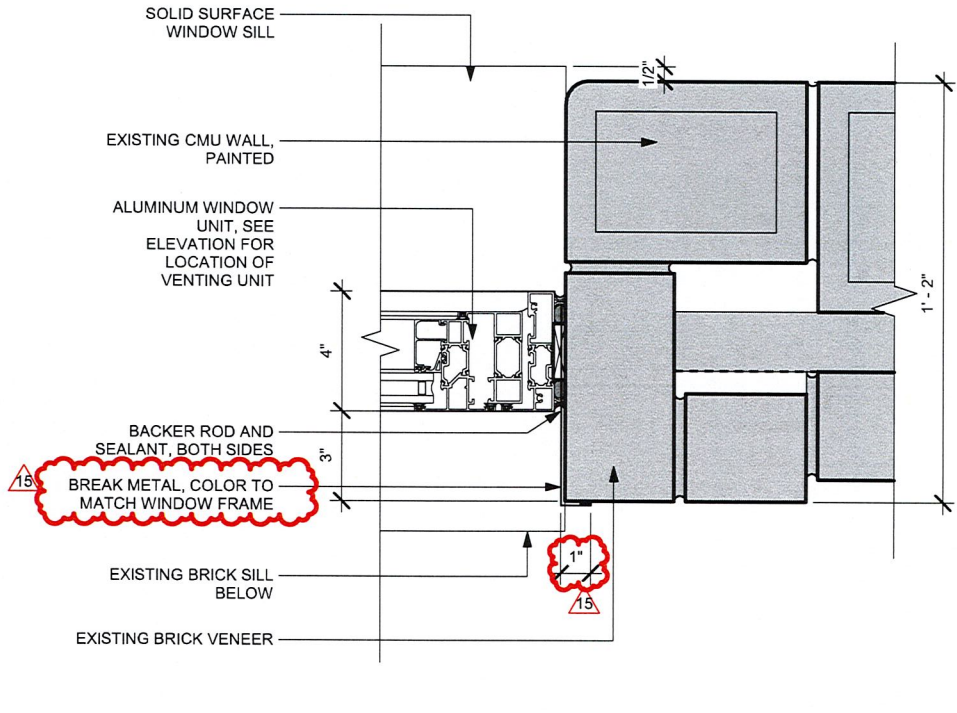

② ALUMINUM WINDOW JAMB @ EXISTING WALL - RFP-5
3" = 1'-0"



studio **kremer** architects
1231 S Shelby St, Louisville, KY 40203
502-499-1100 fax 502-499-1100
s t u d i o

BULLITT COUNTY PUBLIC SCHOOLS
BERNHEIM MIDDLE SCHOOL RENOVATION

700 Audubon Drive

title / description:
WINDOW JAMB MODIFICATION

project no.: 2022-36
date: 10/19/2023
drawn by: SBS
checked by: CMV
scale: 3" = 1'-0"
reference dwg: A6.6

RFP-5.2

10/19/2023 5:27:01 PM

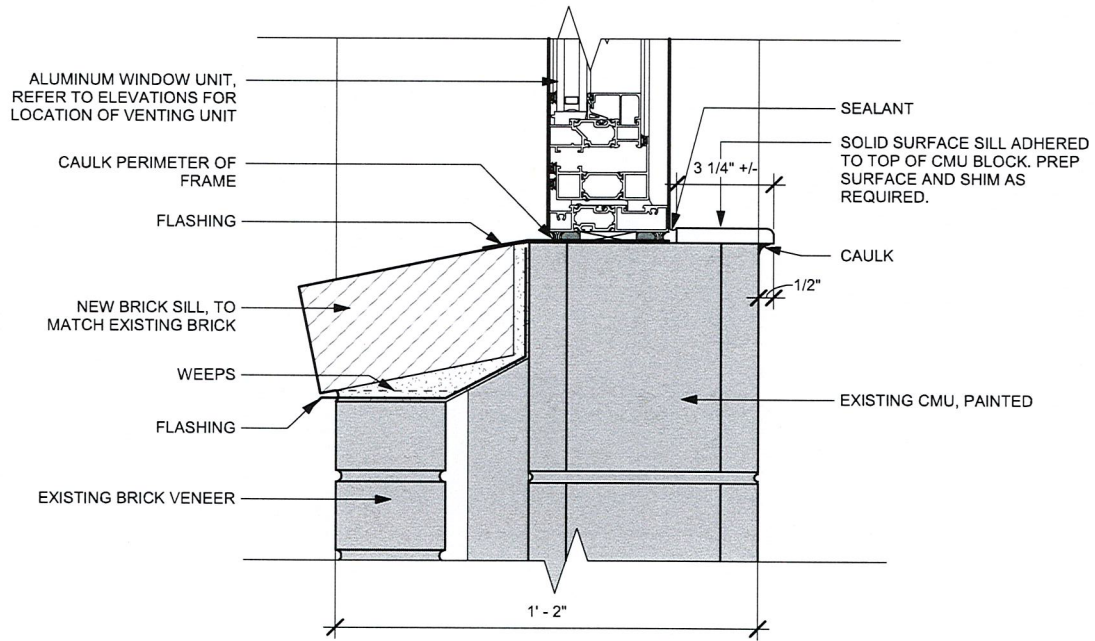

① ALUMINUM WINDOW SILL @ NEW BRICK SILL- RFP-5
3" = 1'-0"



studio **kremer** architects
1231 S Shelby St, Louisville, KY 40203
502.499.1100 FAX 502.499.1100
S T U D I O

BULLITT COUNTY PUBLIC SCHOOLS

BERNHEIM MIDDLE SCHOOL RENOVATION

700 Audubon Drive

title / description:
WINDOW DETAILS

project no.:	2022-35	sketch no.:	
date:	10/19/2023	SRS	
drawn by:	CNV		
checked by:	CNV		
scale:	3" = 1'-0"	reference dwg:	

RFP-5.3

10/19/2023 5:27:01 PM

Change Order Request 8 - PCO #24 - RFP-6 Break Metal Column Wrap

622-Bernheim Middle School Renovation

11/3/2023



Summary of Work

RFP-6 Break Metal Column Wrap

Scope - Subcontractor	Description of Scope	Cost
1 Bernheim Middle School		\$390.00
1.1 Glazing & Storefronts - Stanley Schultze	RFP-6 Add 13'-4" break metal wrap at column	\$390.00

\$390.00

Fee	10.00%	\$39
Bond	1.00%	\$4

Total Amount	\$433
---------------------	--------------

Approved By:

Submitted By:

_____ *Joseph G. Hyatt*

Date:

Date:

_____ 11/3/2023

Lyons, Tonya

To: Mike Bale
Subject: RE: Bernheim MS- RFP-6 in response to RFI-31

Thanks!

Tonya Lyons

Project Engineer

CALHOUN CONSTRUCTION

7707 National Turnpike, Suite 400

Louisville, KY 40214

Office (502)493-1332

Cell (770)241-9227

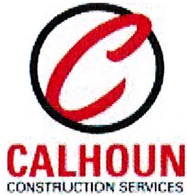

From: Mike Bale <mbale@stanleyschultze.com>
Sent: Thursday, November 2, 2023 2:55 PM
To: Lyons, Tonya <TonyaLyons@calhounconstructs.com>
Cc: Pittard, Joel <joelpittard@calhounconstructs.com>
Subject: RE: Bernheim MS- RFP-6 in response to RFI-31

To wrap the column to 13'=4" \$390.00

Thank you
Michael Bale
Project Manager



849 South 6th Street
Louisville, KY 40203
502-585-4256
502-585-4496 (Fax)
502-592-7620 (Mobile)
mbale@stanleyschultze.com
www.stanleyschultze.com

From: Lyons, Tonya <TonyaLyons@calhounconstructs.com>
Sent: Thursday, November 2, 2023 1:40 PM
To: Mike Bale <mbale@stanleyschultze.com>
Cc: Pittard, Joel <joelpittard@calhounconstructs.com>; Lyons, Tonya <TonyaLyons@calhounconstructs.com>
Subject: FW: Bernheim MS- RFP-6 in response to RFI-31

CAUTION: This email originated from outside of the organization. Do not click links or open attachments unless you recognize the sender and know the content is safe.

Hi Mike,

Please see attached RFP-6 and provide pricing.

Thanks,

Tonya Lyons

Project Engineer

CALHOUN CONSTRUCTION

7707 National Turnpike, Suite 400

Louisville, KY 40214

Office (502)493-1332

Cell (770)241-9227

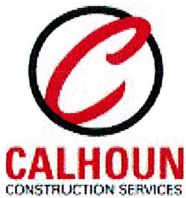

From: Stephanie Satterfield <stephanie@studiokremer.com>

Sent: Thursday, November 2, 2023 11:46 AM

To: Tony Roth <tony.roth@bullitt.kyschools.us>; Lyons, Tonya <TonyaLyons@calhounconstructs.com>; Thompson, Laney <LaneyThompson@calhounconstructs.com>; Dirks, Devin <DevinDirks@calhounconstructs.com>; Pittard, Joel <joelpittard@calhounconstructs.com>; Goad, Grant <grantgoad@calhounconstructs.com>

Cc: Cate Noble Ward <Cate@studiokremer.com>

Subject: Bernheim MS- RFP-6 in response to RFI-31

All,

Please provide pricing for the attached RFP-6 that is in direct response to RFI-31 regarding the jamb condition at C2.

Thank you,

Stephanie Satterfield, Assoc. AIA

Architectural Designer



studio kremer architects

1231 S Shelby St, Louisville KY 40203

TEL 502.499.1100 x2525

FAX 502.499.1101

studiokremer.com

REQUEST FOR PROPOSAL

PROJECT:	Bernheim Middle School Renovation Shepherdsvile, KY	REQUEST FOR PROPOSAL NO.:	06
OWNER:	Bullitt County Public Schools 1040 Highway 44 East Shepherdsvile, KY 40165	DATE:	2-Nov-2023
TO CONTRACTOR:	Calhoun Construction Services, Inc. 7707 National Turnpike Louisville, KY 40218	ARCHITECT:	Studio Kremer Architects 1231 S Shelby Street Louisville, KY 40203
		ARCHITECT'S PROJECT NO.:	2022-36 BG# 23-051

Please submit an itemized quotation for changes in the Contract Sum and/or Time incidental to proposed modifications to the Contract Documents described herein.

THIS IS NOT A CHANGE ORDER NOR A DIRECTION TO PROCEED WITH THE WORK DESCRIBED HEREIN

Description:

Provide price proposal for the following:

Item 1:

REFERENCE RFP-6

- Modified Curtain Wall C2 jamb detail to include break metal to wrap column. The interior CMU back up wall shall stop on outside face of structural column.

Attachments:

PDF: RFP-6

ISSUED:	2-Nov-2023	ARCHITECT:	studio kremer architects
CONTRACTOR:	Calhoun Construction Services, Inc.	BY:	Stephanie Satterfield

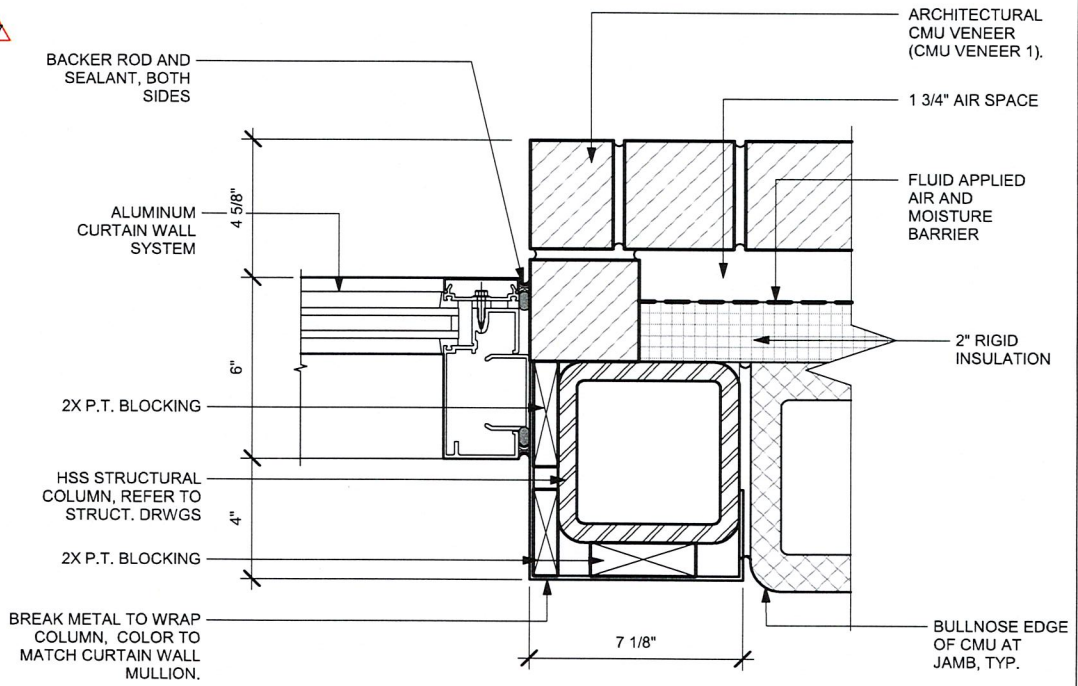
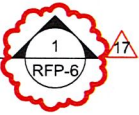
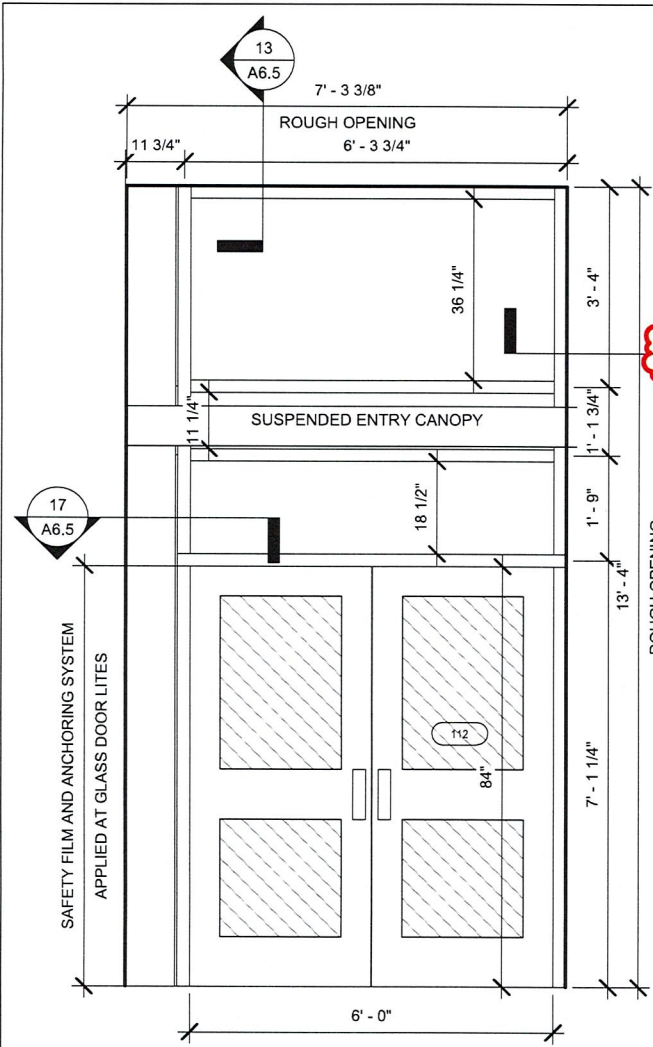

1 CURTAIN WALL JAMB @ COLUMN- RFP-6
3" = 1'-0"

THERMALLY BROKEN CURTAIN WALL SYSTEM, 6" DEEP FRAME W/ 1" INSULATED GLAZING

PROVIDE WINDOW PVC FILM AT DOOR AT EXTERIOR SIDE. DESIGN TBD BY SCHOOL.



studio **kremer** architects
1231 S Shelby St, Louisville, KY 40203
502.498.1100 FAX 502.498.1100
S T U D I O

BULLITT COUNTY PUBLIC SCHOOLS
BERNHHEIM MIDDLE SCHOOL RENOVATION

700 Audubon Drive

RFI-31

title / description:
C2 JAMB DETAIL

project no.:	2022-36	sketch no.:	
date:	11/02/2023	drawn by:	SBS
checked by:	CMN	created by:	As indicated
scale:	As indicated	reference only:	A6.2

RFP-6

11/2/2023 11:38:07 AM